

APPENDIX E – Operations Plan

Exhibit K-2
Operations Plan

FLORENCE COPPER, INC.
UIC PERMIT APPLICATION
FLORENCE COPPER PROJECT – PRODUCTION TEST FACILITY

EXHIBIT K-2: PRODUCTION TEST FACILITY OPERATIONS PLAN

Table of Contents

Table of Contents 1

List of Figures..... 1

List of Tables 1

List of Appendices..... 1

INTRODUCTION..... 2

OPERATIONS..... 2

Pre-Operational Review 2

Injection System and Monitoring Devices..... 3

Injection Pressures..... 3

Injection Monitoring and Controls..... 3

Recovery System Monitoring and Controls..... 4

Hydraulic Control 5

OPERATIONAL MONITORING 5

Emergency Response/Contingency Plan Requirements Emergency Conditions..... 5

Emergency Response Actions 5

RECORDKEEPING AND REPORTING 6

Daily Operations Log..... 6

Quarterly Monitoring Report..... 6

List of Figures

- Figure 1 Injection/Recovery System Overview
- Figure 2 Injection/Recovery Well System Controls

List of Tables

- Table 1 Production Test Facility Operations Plan (Monitoring and Response Requirements)

List of Appendices

- Appendix A Estimated Composition of PTF ISCR Process Solutions

INTRODUCTION

This document provides a description of monitoring, control, and reporting requirements associated with the operation of the Florence Copper Project (FCP) in-situ copper recovery (ISCR) Production Test Facility (PTF). The methods and procedures described in this Operations Plan incorporate the detailed provisions contained in Attachments H, K, O, and P of the UIC Permit application that Florence Copper, Inc. (Florence Copper) submitted to the United States Environmental Protection Agency (USEPA) for operation of the PTF. The injection and recovery system will employ devices for metering flow and pressure, and for manually or automatically shutting down flow when alarm conditions occur. The metering devices will be monitored in a central control room and will provide sufficient information to allow the operator to maintain hydraulic control on a daily basis. Within the control room, the operator will have direct access to the necessary controls for shutting down the injection and extraction systems in response to unanticipated conditions.

Table 1, *Production Test Facility Operations Plan (Monitoring and Response Requirements)*, provides a summary of methods and procedures related to PTF operations. Table 1 identifies major components of the ISCR process; devices by which the components are to be monitored; the operating conditions to be monitored; possible causes of those conditions; immediate responses required if conditions exceed specified limits; and required follow-up actions. The monitoring devices will be electronically linked to the facility control room in order to provide a continuous assessment of conditions in the well field area, the pipeline corridor, and process area.

OPERATIONS

Pre-Operational Review

Before commencing PTF operations, operations personnel will conduct a pre-operational review of all equipment, monitoring devices, and procedures to ensure that the operations comply with the following permit conditions.

1. Mechanical integrity tests (Part I and Part II) have been conducted on all ISCR wells in the PTF well field, and all wells have passed the tests.
2. All wells have been completed such that they will not inject solutions within the uppermost 40 feet of the oxide zone (injection exclusion zone).
3. All core holes and non-Class III wells located within 500 feet of the PTF well field have been abandoned in accordance with the approved Plugging and Abandonment Plan.
4. Allowable injection pressure set not to exceed 0.65 pounds per square inch per foot (psi/ft) for each injection well.
5. Fresh groundwater has been injected, as needed, to assess the hydraulics of the injection and recovery patterns and to confirm that all monitoring devices and controls are in working order.

The operator will perform aquifer pump tests prior to injection in order to evaluate subsurface characteristics of the Bedrock Oxide Zone, overlying basin fill units, and the confining Middle Fine Grained Unit within the PTF Area of Review (AOR). Test results will be reported to the Arizona Department of Environmental Quality (ADEQ) in accordance with Aquifer Protection Permit (APP) requirements and to USEPA in accordance with UIC Permit conditions. Results of the aquifer tests will be compared to parameters used in the groundwater flow model, and the model parameters will be revised accordingly if the parameters are significantly different from those used in the model.

Injection System and Monitoring Devices

The injection system consists of individual injection wells, pumps, manifolds, piping, flow meters, and related controls. Manifolds will be used to distribute lixiviant to injection wells and to collect pregnant leach solution (PLS) from recovery wells.

Injection Pressures

The proposed Class III injection wells may be operated in one of two modes: pressurized at the well head or under atmospheric well head pressures.

To ensure that injection pressures do not induce additional fracturing of the oxide zone, UIC Permit No. AZ396000001 established a fracture gradient limit of 0.65 psi/ft. Maximum injection pressures are determined by multiplying the fracture gradient limit (0.65 psi/ft) by the depth from the top of well casing to the top of the injection interval. This method of calculating maximum injection pressures reflects the pressure generated by the weight of the column of raffinate and an additional pressure applied by mechanical means to achieve the maximum allowable injection pressure at depth. Florence Copper proposes to apply the same pressure limit cited in UIC Permit No. AZ396000001.

Injection Monitoring and Controls

Mechanical controls and monitoring devices incorporated into the injection system include:

- a pressure transducer at each injection well head;
- a flow meter at each injection manifold for measuring flow rates (gallons per minute [gpm]);
- a totalizing flow meter for measuring cumulative flow (gallons) into each injection manifold;
- an isolation valve at each injection well;
- a flow meter at each injection well for measuring flow rates (gpm);
- a valve at each injection well for controlling flow;
- a pressure transducer to measure annular pressure above the packer; and
- a pressure transducer to measure pressure in the injection zone.

A schematic depicting well field controls is included as Figure 1, and well controls as Figure 2.

Operators will use the injection well head pressure transducers to monitor injection pressures for loss of mechanical integrity, and ensure that the maximum allowable injection pressures are not exceeded at the wellheads. Allowable injection pressure will be calculated for each injection well. Actual pressures measured at each well head will be compared to the maximum allowable pressure(s) for the well, and will be adjusted as necessary to ensure injection pressures are within calculated allowable limits.

Inflatable packers may be used in injection wells to isolate each or both of the lower two screened well intervals. In the event that the operator intends to inject into all three of the screened intervals simultaneously, no packer will be used. Consequently, there will be open well screen above the packer wherever a packer is used in an injection well.

Operators will also use gauges and meters at each injection manifold as devices for monitoring injection pressures and flows on a manifold-by-manifold basis.

Every 24 hours, the totalized flows from all of the injection manifolds will be summed and compared to the summed totalized flows from all of the manifolds from recovery wells. If the summed total flow out of the well field exceeds the total flow into the well field, and if head elevations observed in the observation wells are greater than head elevations observed at the paired recovery wells, hydraulic control is confirmed. If the

summed total flow out of the well field does not exceed the total flow into the well field, or if head elevations observed at the observation wells are not greater than the head elevations observed at the paired recovery wells, adjustments to recovery and/or injection flow rates will be made accordingly to restore hydraulic control.

Planned PTF injection and recovery rates will be approximately 240 and 300 gpm, respectively. Operational and well performance considerations may require that these pumping and extraction rates vary slightly over time. Although the planned injection and recovery rates provide for 25 percent greater extraction than recovery, it is anticipated that hydraulic control can be maintained with a smaller amount of excess extraction. During PTF operations, injection will not be allowed to exceed 240 gpm, and extraction will not be allowed to fall below 110 percent of the injection rate on a daily average basis unless prior approval of a lower percentage is obtained from USEPA. Irrespective of operational injection and recovery rates, hydraulic control has only been confirmed when more solution is extracted than is injected and an inward groundwater gradient has been demonstrated between each observation well and inner recovery well pair.

Reduced flow in an injection well may be due to changes in formation characteristics or clogging of the formation or the well screens. A sudden increase in flow may indicate a break/failure of the well casing. If a casing breach is believed to have occurred, the operator will shut down that well by closing the well head isolation valve and will conduct relevant inspections. Inspections and related reporting will be conducted in accordance with Plans for Well Failures (Attachment O).

The injection and recovery systems will be connected to one or more tank farms near the PTF. The tank farms will include tanks fitted with a high-level alarm and level indicators. Both alarm and level indicator signals will be routed to the control room. An alarm will actuate if either a line fails or the tank high level is exceeded. The feed pump to the tank will be disabled automatically. Spilled solutions will be captured in a lined collection sump able to contain 110 percent of the volume of the tank and line. The spilled volume will be pumped back into the circuit for reuse.

Solutions pumped through pipelines located in pipeline channels between the PTF and the process area will be metered for flow and pressure. An electronic monitoring system will alarm if a pump fails, flow is interrupted, or flow is not in logical mode when a pump is activated. Loss of pressure or pressure exceeding a high setting will cause the pump to automatically shut down. In the event of such an occurrence, the plant operator will inspect the system. A broken line will be repaired within 48 hours and spilled solutions captured in spill control sumps in the lined channels will be pumped back into the process systems or to the water impoundment.

Recovery System Monitoring and Controls

The recovery system is similar to the injection system. It is comprised of individual recovery wells, pumps, recovery manifolds, piping, and related meters and controls, and includes:

- a continuous reading flow meter (gpm) at each recovery manifold;
- a totalizing flow meter (gallons) at each recovery manifold;
- an isolation valve at each recovery well;
- a flow meter at each recovery well; and
- a pressure transducer within perimeter and selected recovery wells for measuring head/water elevation within an IRZ (to assess hydraulic control).

The flow meters on the recovery manifolds will allow the operators to monitor recovery flow rates and use the data to compare against injection flow rates as described above. As necessary, recovery flow can be adjusted in the manifolds to ensure that flow out of the operational unit exceeds the flow of lixiviant and any other process solution into the operational unit. Inspections and related reporting will be conducted in accordance with Plans for Well Failures (Attachment O.)

Hydraulic Control

Hydraulic control must be maintained from the time that lixiviant injection begins until the groundwater quality in the injection zone has been restored to a quality that meets closure criteria in the APP and the UIC Permit.

Hydraulic control is defined as a condition involving an inward groundwater gradient. It is maintained by pumping more solution from the injection zone than is injected, and is used to prevent in-situ solutions from migrating beyond the injection zone.

In-line flow meters will be used to monitor and verify that the volume of PLS pumped from recovery wells exceeds the amount of lixiviant injected to confirm hydraulic control. In addition, the presence of an inward hydraulic gradient will be monitored on a daily basis by comparing water levels in paired wells along the perimeter of the injection zone. Paired wells along the perimeter of the injection zone include an inner recovery well and an outer observation well. Hydraulic control is confirmed when the water level in the outer observation well is higher than the water level in the inner recovery well of each well pair.

Hydraulic control has been confirmed when more solution is extracted than is injected and an inward groundwater gradient has been demonstrated between each observation well-inner recovery well pair.

OPERATIONAL MONITORING

Table 1 (attached) summarizes operational monitoring methods and procedures that will be used during PTF operations. Table 1 is designed to provide for the identification and correction of any problem related to the storage or flow of injected solutions before the solutions reach surface soils, the vadose zone, or groundwater outside the injection zone. The monitoring methods and procedures are also designed to monitor and maintain hydraulic control and thereby prevent injected solutions from migrating beyond the PTF well field. Table 1 is not intended to cover the sampling and analysis of groundwater or process solutions because of the complexity of the required equipment and procedures. However, references are provided in Section 1 for all related sampling and analysis requirements.

Emergency Response/Contingency Plan Requirements Emergency Conditions

The following conditions will cause activation of the contingency plan.

1. Spills of sulfuric acid, raffinate, or PLS outside containment structures that are in excess of the reportable quantities set forth in 40 CFR 302 et seq.
2. Loss of hydraulic control within an operational unit for more than 48 consecutive hours. For purpose of this requirement, loss of hydraulic control means that the amount of fluids injected during a 48-hour period exceeds the amount of fluid recovered during the same 48-hour period, and/or that the average head reading for any observation pair for a 48-hour period indicates a flat or outward gradient.
3. Failure of transducers in any observation pair for more than 48 hours.

Emergency Response Actions

The occurrence of any of the conditions described above will result in:

1. The activation of the notification procedures set forth in the APP.
2. Immediate containment of the spilled material, return of collected liquids to the process or to the evaporation ponds, disposal of contaminated soils in the water impoundment(s), and disposal of other debris in approved off-site facilities.

3. Immediate cessation of injection until such time that hydraulic control has been established and recovery wells have operated a sufficiently long period of time to compensate for the amount of fluid that was injected in excess of the amount recovered during the 48-hour period.

RECORDKEEPING AND REPORTING

Operational reporting will be conducted at two levels: daily and quarterly. Florence Copper operators will complete a daily operations log that includes each of the daily monitoring requirements and calculations described above, and other entries related to the injection and recovery process. These logs will be maintained on site and be available for inspection for a period of two years. Quarterly monitoring reports will be submitted to ADEQ and USEPA, and will include summaries of pertinent data from the daily operations log, as well as water quality sampling results for the point-of-compliance (POC), operational monitoring, and supplemental monitoring wells. Copies of the quarterly reports will be maintained on site until commencement of the post-closure period.

Daily Operations Log

The daily operations log will include the following:

- Daily cumulative flow rates for each of the injection and recovery manifolds.
- Daily cumulative total flow rates for the all of in the injection and recovery manifolds combined.
- Daily average water level readings for each perimeter/recovery well pair.
- List of injection and recovery wells shut down in response to alarm conditions, and actions taken to correct the alarm conditions noted. This information will include well identification, shut down time, and estimate of excess injection flow occurring prior to shut down.

Quarterly Monitoring Report

Quarterly monitoring reports will be submitted to ADEQ and USEPA within 45 days following the end of each calendar quarter. The quarterly reports will include:

- A table showing POC monitoring well, operational monitoring well, and supplemental monitoring well analytical results and alert levels with a narrative summary of those results. Supplemental monitoring wells include M55-UBF, M56-LBF, M57-O, M58-O, M59-O, M60-O, and M61-O.
- Results of monthly analysis of organics in raffinate.
- A table and graphs showing daily average head in the paired perimeter and observation wells.
- A table and graph showing daily cumulative injection and recovery flow in each active production unit over the reporting period.
- Results of monitoring required by 40 CFR 146.33(b)(i) whenever the injection fluid is modified to the extent that previously reported analyses are incorrect and incomplete.
- Results of mechanical integrity testing completed during the reporting period.
- A map showing current operational unit status.
- A list of wells and core holes abandoned during the reporting period, and a list of wells and core holes to be abandoned during the next reporting period.

Forecast compositions of injected and recovered solutions are provided in Appendix A. The forecast solution compositions listed in Appendix A were derived using a geochemical model and best available data describing formation conditions and solution geochemistry. This information is included with this Operations Plan to provide an example of what typical injected and recovered solution composition may be. As noted in Attachment H, Section H.6.4 of this Application, no solution stacking is proposed during PTF operations. Actual solution compositions may vary from those listed in Appendix A.

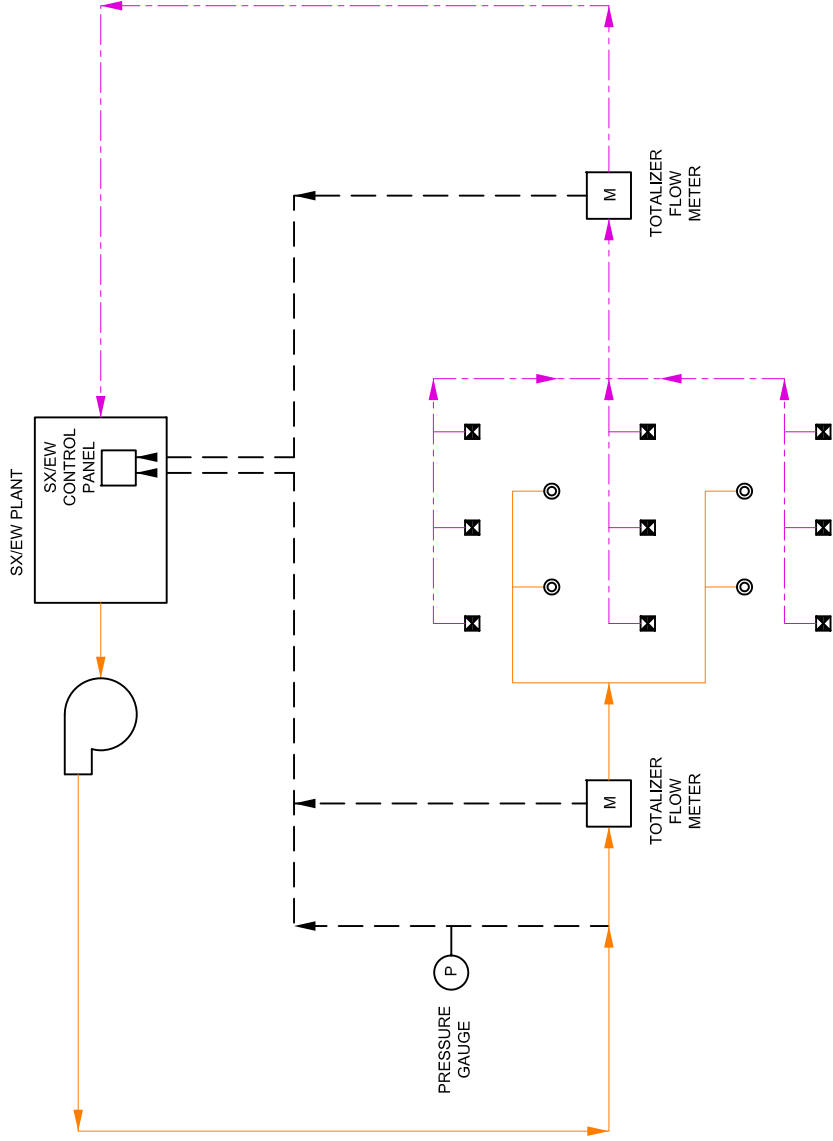

LEGEND:

- ☒ RECOVERY WELL
- ◎ INJECTION WELL

HALEY & ALDRICH
FLORENCE COPPER, INC.
FLORENCE, ARIZONA

**INJECTION/RECOVERY SYSTEM
OVERVIEW**

FLORENCE COPPER INC.
SCALE: NOT TO SCALE
MAY 2014

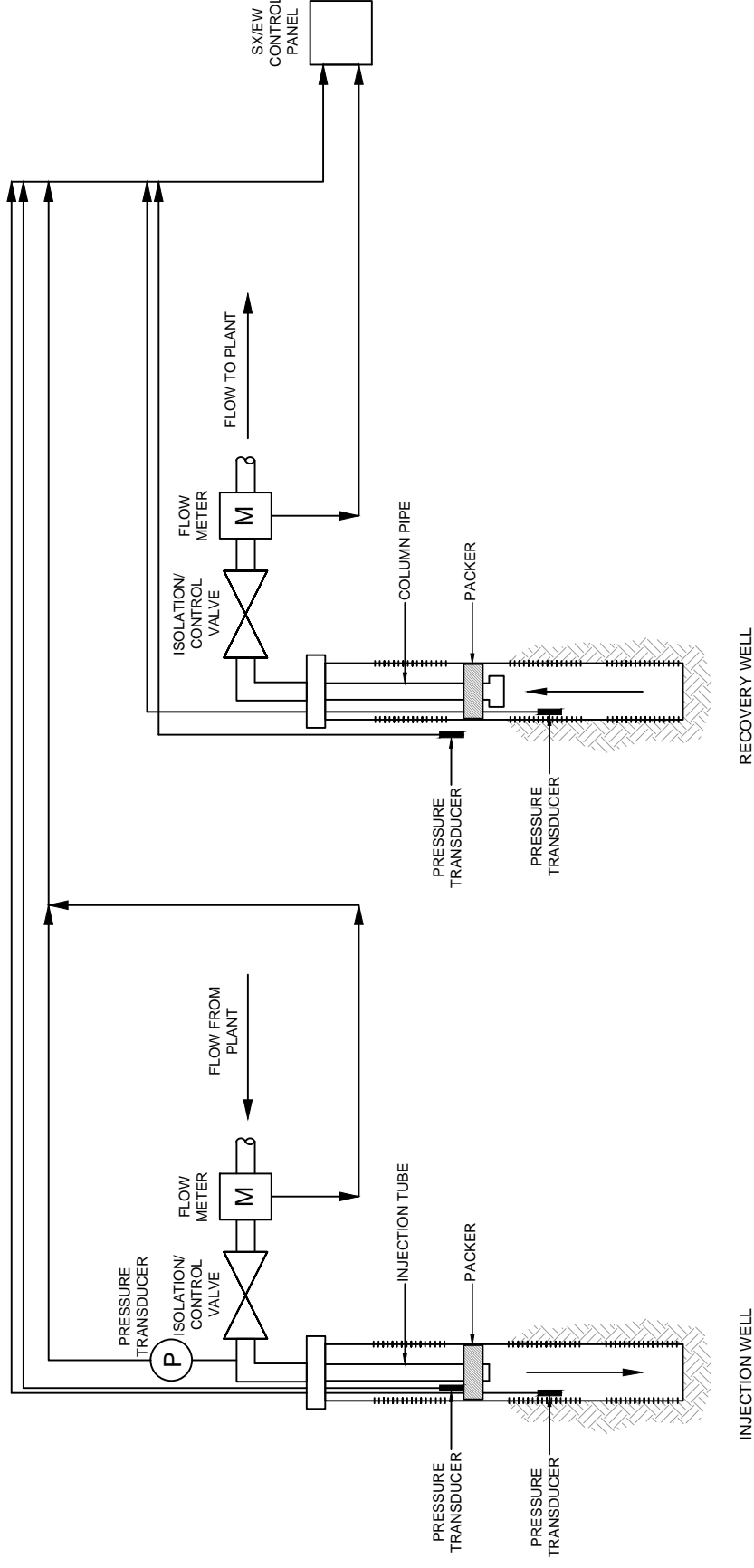

RECOVERY WELL

INJECTION WELL



**INJECTION/RECOVERY WELL
SYSTEM CONTROLS**

*NOTE: TYPICAL SCREEN AND PACKER PLACEMENT SHOWN

FLORENCE COPPER, INC.
FLORENCE, ARIZONA

FLORENCE COPPER, INC.
MAY 2014

Table 1. ISCR Phase 1 Facility (PTF) Operations Plan (Monitoring and Response Requirements)

Component	Monitoring Device	Condition	Possible Cause*	Response	Follow-up Action	
Injection System	Injection Manifold and Pipeline	Pressure exceeds upper setting	Improper pump setting, clogged screens, reduced formation permeability, obstructed well or equipment.	Alarm in control room, stop flow at injection manifold	Restart injection at lower flow rates.	
		Pressure below lower setting	Line break, casing or screen breach.	Alarm in control room, stop flow at injection manifold	Repair system before restarting flow to injection manifold.	
	Flow Meter	Flow rate too high	Improper pump setting, line break, injection well short circuit.	Alarm in control room, stop or reduce flow at injection manifold	Inspect/repair injection system, increase flow rates in adjoining recovery manifolds as necessary.	
		Flow rate too low	Improper pump setting, clogged screens, reduced formation permeability, obstructed well or equipment.	Alarm in control room, reduce flow rates in adjoining recovery manifolds	Inspect/repair system, adjust injection flow rate as necessary.	
	Totalizing Flow Meter	Daily total flow: Total in > total out	Loss of hydraulic control.	Reduce injection flow rate or increase recovery flow rate	Follow Part II.H.1 of UIC Permit and related reporting and record-keeping requirements.	
		No flow	Power loss, line break, instrument failure.	Reduce recovery rate in adjacent wells	Repair system, adjust flow rates as necessary.	
	Injection Well Head	Flow Meter	Flow rate too high	Improper pump setting, injection well short circuit, damaged well casing or equipment.	Reduce injection flow rate as necessary	Inspect/repair injection system.
			Flow rate too low	Improper pump setting, reduced formation permeability, obstructed well or equipment.	Reduce flow rates in adjoining recovery manifolds	Inspect/repair system, adjust injection flow rate as necessary.
		Transducer	Pressure exceeds upper limit	Improper pump setting, clogged screens, reduced formation permeability, obstructed well or equipment.	Alarm in control room, stop flow at injection manifold	Restart injection at lower flow rates.
			Pressure below lower limit	Line break, casing or screen breach.	Alarm in control room, stop flow at injection manifold	Repair system before restarting flow to injection manifold.
Recovery System	Injection Well Annular Space	Fluid level too high	Loss of packer pressure, injection tubing failure, formation bypass to upper screened zone	Inspect packer pressure, pressure test packer lines, inspect injection tubing, inspect fluid level conditions at other injection wells	Repair or replace packer or inflation equipment if necessary, replace damaged injection tubing, monitor fluid level conditions	
		Flow rate too high	Improper pump setting.	Reduce recovery manifold flow rates as necessary	Inspect/repair system, reduce recovery flow rate as necessary.	
	Recovery Manifold and Pipeline	Flow rate too low	Improper pump setting, reduced formation permeability, obstructed well or equipment.	Increase pump rate	Inspect/repair system, reduce injection flow rate in adjacent manifolds as necessary.	
		Daily total flow: Total in > total out	Loss of hydraulic control.	Reduce injection flow rate or increase recovery flow rate as necessary	Follow Part II.H.1 of UIC Permit and related reporting and record-keeping requirements.	
	Recovery Well Head	Flow Meter	No flow	Power loss, instrument failure.	Alarm in control room, stop injection in adjoining injection wells	Repair system before restarting injection.
		Pressure Transducer (in selected wells only)	Fluid level too high	Improper pump setting, short circuit in adjacent injection wells.	Alarm in control room, adjust pump setting, inspect well, reduce injection in adjoining wells as necessary	Inspect/repair recovery well and adjacent injection wells as necessary.
	Raffinate/Lixiviant Tanks	Level Indicators	Fluid level too low	Improper pump setting, clogged screen, reduced formation permeability.	Alarm in control room, automatic shut-off of pump	Evaluate formation, restart well at lower flow rate if necessary.
			Fluid level too high	If in production mode, insufficient flow to injection wells or insufficient raffinate bleed to water impoundment. If in recirculation mode, too much flow from PLS tanks.	Alarm in control room, automatic shut-off of pumps at raffinate tanks	Inspect/repair injection system, adjust pump settings at raffinate tank.
	ISCR Area Tanks		Fluid level too low	If in production mode, flow too high to injection manifolds or too much raffinate bleed to water impoundment. If in recirculation mode, insufficient flow from PLS tanks.	Alarm in control room, automatic shut-off of injection pumps	Inspect/repair injection/raffinate system, adjust pumps at raffinate tank.

Table 1. ISCR Phase 1 Facility (PTF) Operations Plan (Monitoring and Response Requirements)

Component	Monitoring Device	Condition	Possible Cause*	Response	Follow-up Action
ISCR Area Tanks (continued)	Level Indicators	Fluid level too high	Recovery rate too high, or flow to SX/EW too low if in production mode, or flow to raffinate tank too low if in recirculation mode.	Alarm in control room, automatic shut-off of recovery and injection wells	Inspect/repair injection system, adjust pumps to PLS pond and injection manifolds.
		Fluid level too low	Recovery rate too low or flow to SX/EW too high if in production mode, or flow to raffinate tank too high if in recirculation mode.	Alarm in control room, automatic shut-off of injection wells	Inspect/repair injection/recovery system; inspect/repair lines to raffinate tanks.
Beneficiation Area Tanks	Level Indicators	Fluid level too high	If in production mode, insufficient flow to injection wells or insufficient raffinate bleed to water impoundment. If in recirculation mode, too much flow from PLS tanks	Alarm in control room, automatic shut-off of pumps at raffinate tanks	Inspect/repair injection system, adjust pump settings at raffinate tank.
		Fluid level too low	If in production mode, flow too high to injection manifolds or too much raffinate bleed to water impoundment. If in recirculation mode, insufficient flow from PLS tanks.	Alarm in control room, automatic shut-off of injection pumps	Inspect/repair injection/raffinate system, adjust pumps at raffinate tank.
		Fluid level too high	Recovery rate too high, or flow to SX/EW too low if in production mode, or flow to raffinate tank too low if in recirculation mode.	Alarm in control room, automatic shut-off of recovery and injection wells	Inspect/repair injection system, adjust pumps to PLS pond and injection manifolds.
		Fluid level too low	Recovery rate too low or flow to SX/EW too high if in production mode, or flow to raffinate tank too high if in recirculation mode.	Alarm in control room, automatic shut-off of injection wells	Inspect/repair injection/recovery system; inspect/repair lines to raffinate tanks.
Pipeline Corridor	Liquid Detectors	Liquid present	Precipitation or leak.	Alarm in control room. If not raining, arm immediate shut-off of associated pumps.	Assess liquid; return liquid to plant or water impoundment; evaluate and repair pipeline if needed.
Runoff Pond	Liquid Level Indicator	Liquid accumulating in sump	Precipitation, leak, spill, wash down.	Alarm in control room; determine nature of liquid. Pump to PLS, raffinate tanks, or neutralizing unit/water impoundment depending on volume and source of liquid.	Inspect sump to confirm that accumulating liquids are being removed.
Water Impoundment	Leak Collection and Removal System (LCRS)	Presence of liquid in sump above pump-down level	Leak in upper (primary) liner.	Measure and record volume of liquid removed from LCRS sump, determine if ALR or RLL is exceeded.	If ALR or RLL is exceeded, follow APP contingency plan and related reporting and record-keeping requirements.
External Monitoring	Paired Recovery/Observation Wells	Pressure Transducer	Loss of hydraulic control.	Increase recovery flow rate or decrease injection flow rate as necessary	Follow Part II.H.1 of UJC Permit and related reporting and record-keeping requirements.

*Faulty monitoring devices will be evaluated as a possible cause of each listed condition.

APPENDIX A

Estimated Composition of PTF ISCR Process Solutions



Table 3.1. Estimated Composition of Pilot Test Facility Process Solutions
Page 1 of 2

Analyte	Arizona Water Quality Standard (mg/L)	Forecasted Concentration (mg/L ^a)							
		Composition of 98% H ₂ SO ₄	PLS	Raffinate	Pregnant Electrolyte (SX Solution)	Water Impoundment Solution with 9 g/L Lime Treatment	Water Impoundment After Evaporation (mg/kg)	Groundwater After Block Rinsing	Makeup Water ^b
Metals									
Aluminum	None	—	1,642	1,639	110	1,569	63,380	0.30	<2.0
Antimony	0.006	0.05–0.15	—	—	0.10	—	—	<0.2	<0.2
Arsenic	0.05	0.1–0.4	1.32	1.32	0.06	1.33	53.58	<0.0005	<0.0005
Barium	2	—	0.55	0.55	< 0.2	0.55	22.14	<0.05	<0.05
Beryllium	0.004	—	0.09	0.09	—	0.09	3.59	<0.002	<0.002
Cadmium	0.005	—	0.24	0.24	25.0	0.24	9.74	<0.002	<0.002
Calcium	None	—	449	448	90	4,180	168,740	11.8	61
Chromium	0.1	—	0.74	0.73	15	0.74	29.8	<0.03	<0.03
Cobalt	None	—	1.1	1.09	15	1.1	44.27	<0.1	<0.1
Copper	None	0.2–0.5	2,080	208	51,000	208	8,410	1.44	0.044
Iron	None	7–14	1,314	1,310	1,650	1	26.41	<0.001	0.34
Lead	0.05	0.1–0.7	0.44	0.44	< 1.0	0.44	17.7	<0.04	<0.04
Magnesium	None	—	1,204	1,202	160	1,198	48,430	24.40	14
Manganese	None	0.05–0.15	15.3	15.3	0.014	15.3	620	0.05	<0.02
Mercury	0.002	—	—	—	< 0.01	—	—	<0.001	<0.001
Nickel	0.1	0.07–0.2	2.3	2.3	35	2.3	93	<0.05	<0.05
Potassium	None	—	372	372	< 0.01	344	13,900	55.0	6.2

^a Unless otherwise noted

^b Makeup water results from well PW2-1 sampled March 12, 2014 (Turner Laboratories [Tucson] work order 14C0493)

^c Turner Laboratories result

mg/L = Milligrams per liter PLS = Pregnant leach solution mg/kg = Milligrams per kilogram
H₂SO₄ = Sulfuric acid g/L = Grams per liter — = Not estimated



Table 3.1. Estimated Composition of Pilot Test Facility Process Solutions
Page 2 of 2

Analyte	Arizona Water Quality Standard (mg/L)	Forecasted Concentration (mg/L ^a)							Makeup Water ^b
		Composition of 98% H ₂ SO ₄	PLS	Raffinate	Pregnant Electrolyte (SX Solution)	Water Impoundment Solution with 9 g/L Lime Treatment	Water Impoundment After Evaporation (mg/kg)	Groundwater After Block Rinsing	
Metals (cont.)									
Selenium	0.05	—	0.44	0.4	<0.1	0.4	18	<0.04	<0.04
Silver	None	—	0.11	0.11	<0.01	0.11	1.09	<0.1	<0.1
Sodium	None	—	164.2	163.9	110	164.4	6,640	1,203	120
Thallium	0.002	—	0.55	0.6	0.1	0.6	22	<0.05	<0.05
Zinc	None	0.05–0.75	7.6	7.5	0.06	7.6	305	—	0.095
Anions									
Bicarbonate	None	—	—	<1	<1	1.86	75	3,180	160
Chloride	None	<1	296	295	25	296	11,950	159	160
Fluoride	4	—	230	230	<1	230	9,300	1	<0.5
Nitrate	None	<5	24	24	—	24	974	1.9	1.9
Phosphate	None	—	—	—	<0.5	—	—	<0.5	<0.5
Sulfate	None	954,000	24,226	23,055	214,000	16,780	678,280	507	76
Field Parameters									
TDS	None	—	32,410	29,350	267,483	25,146	—	5,150	550 ^c
pH	None	—	1.57	1.4	0.01	6.2	—	7.0	7.2
Radiochemicals									
Uranium	None	—	4.1	4.1	—	4.1	163	—	0.013

^a Unless otherwise noted

^b Makeup water results from well PW2-1 sampled March 12, 2014 (Turner Laboratories [Tucson] work order 14C0493)

^c Turner Laboratories result

mg/L = Milligrams per liter PLS = Pregnant leach solution

H₂SO₄ = Sulfuric acid g/L = Grams per liter

mg/kg = Milligrams per kilogram

— = Not estimated